



*Stars Management DMCC*

---

**SUBMITTAL**

**ELECTRONIC  
UNIT HEATER  
(KB ECO2S Series)**

---

# Electronic Unit Heater KB ECO2S Series



### Model Code:

KB 24 04 -1 -B2 -ECO  
A B C D E F

A: Series  
B: 20 - 208V, 24 - 240/208V  
C: kiloWatts ( 4 - 15 )  
D: -1 = Single Phase  
E: -B2 = Universal Bracket  
F: -ECO = Electronic Control



- ECO2S Electronic Controller
- Energy efficient 2-Stage Heating
- Remote Control Included
- Large LED Display
- Fan Only and Timer Modes
- Auto Reset High Limit
- Unit Bearing Motor
- Standard Color: Textured Gray with Black Louvers
- Adjustable Louvers
- Spiral Finned Heat Elements
- Universal Bracket Included
- 5-year limited warranty



## ECO2S 2-Stage Unit Heater with IR Remote Control

The ECO2S KB series unit heaters offers unparalleled performance, energy efficiency and user control by incorporating another **King innovation**, the in-built ECO2S electronic thermostat with remote control. Offering energy efficient 2-stage heating, with Eco mode that automatically uses the lowest wattage needed to heat the room, integrated fan only and timer modes, as well as a remote control for simple operation. Designed for use as primary or supplemental heat sources in warehouses, stores or large garages spaces. Spiral steel elements and high CFM ensure even air distribution producing cooler element operation which prolongs the life of the heater. By combining the highest quality components, with a dynamically balanced fan blade, the KB ECO2S unit heater will provide years of trouble-free service and keep heating bills to a minimum. Includes universal wall/ceiling bracket for simple installation.

### ECO2S Electronic Controller Features:

- Electronic control for accuracy
- Energy-saving automatic 2-stage heating
- Large LED display
- Remote control and wall bracket included
- Thermostat timer mode (1-9 Hours)
- Fan only mode
- Built-In fan delay



### Engineering Specifications

*Contractor shall supply and install KB ECO2S Series unit heaters manufactured by King Electrical Mfg. Company. Heaters shall be of the wattage and voltage as indicated on the plans.*

**Construction:** All exterior and interior metal enclosure parts are made from 20 gauge electrogalvanized Steel with a rust inhibiting baked enamel finish. Smooth rounded corners and protective edge trim give an attractive modern appearance.

**Adjustable Outlet Louver:** Louvers direct air up or down as needed for the heating application. Rear Intake Screen: Heavy gauge steel screen protects against foreign objects making accidental contact with the rotating fan blade.

**Spiral Fin Elements:** The metal sheath element is copper brazed with spiral fins then molded into a coil configuration. This combination produces the best heat transfer while eliminating the potential for hot spots by positioning the element in the maximum airflow stream.

**Totally Enclosed Fan Motor:** Permanently lubricated long life unit bearing motor with 20cc of oil. Epoxy-coated motor with enclosed rotor resists moisture and corrosion for long-lasting, trouble-free operation.

**Aluminum Fan Blade:** 5 blade fan mounted directly to the motor shaft for maximum efficiency.

**Auto-Reset Thermal Cutout:** Power is disconnected from the element if an overheated condition occurs. The fan continues to run to dissipate excess heat from the element. The element is re-energized automatically when the normal operating temperature returns.

**Electronic Control:** Up, down temperature mode. Start/Stop. Standard on all heaters. The control voltage is equal to the line voltage (208, 240) for 5kW models. Over 5kW the line voltage control is operating the contactors.

**Easy Installation:** A quick access panel located on the bottom of the heater allows for quick wiring and easy maintenance for the life of the heater. Includes universal wall/ceiling bracket for simple installation.

**Approvals:** cULus (E41422)

# Electronic Unit Heater KB ECO2S Series

## Ordering Information

MODEL	UPC	kilo WATTS	BTUH	PHASE	VOLTS	AMPS	MOTOR HP	CFM	TEMP. RISE	AIR THROW	MAX MOUNT HEIGHT	WT. (lbs.)
KB2404-1-B2-ECO	22037	4	13.5	1	240/208	16.6/14.4	5W	400	38°F	15 ft.	8 ft.	28.5
KB2004-1-B2-ECO	22045	4	13.5	1	208	19.2	5W	400	38°F	15 ft.	8 ft.	28.5
KB2405-1-B2-ECO	22038	5	17	1	240/208	20.8/18	9W	400	40°F	16 ft.	8 ft.	28.5
KB2005-1-B2-ECO	22046	5	17	1	208	24	9W	400	40°F	16 ft.	8 ft.	28.5
KB2406-1-B2-ECO	22039	6	20.5	1	240/208	25/21.6	9W	400	45°F	16 ft.	8 ft.	28.5
KB2006-1-B2-ECO	22047	6	20.5	1	208	28.8	9W	400	45°F	16 ft.	8 ft.	28.5
KB2407-1-B2-ECO	22040	7.5	25.6	1	240/208	31.2/27	16W	600	40°F	20 ft.	9 ft.	28.5
KB2007-1-B2-ECO	22048	7.5	25.6	1	208	36.1	16W	600	40°F	20 ft.	9 ft.	29
KB2410-1-B2-ECO	22042	10	34.1	1	240/208	41.6/36.1	25W	725	44°F	24 ft.	10 ft.	42
KB2010-1-B2-ECO	22050	10	34.1	1	208	48.1	25W	725	44°F	24 ft.	10 ft.	34
KB2412-1-B2-ECO	22043	12.5	42.7	1	240/208	52/45.1	35W	825	48°F	30 ft.	11 ft.	32
KB2012-1-B2-ECO	22051	12.5	42.7	1	208	60.1	35W	825	48°F	30 ft.	11 ft.	32
KB2415-1-B2-ECO	22044	15	51.2	1	240/208	62.5/54.1	35W	925	51°F	33 ft.	12 ft.	37
KB2015-1-B2-ECO	22052	15	51.2	1	208	72.1	35W	925	51°F	33 ft.	12 ft.	37

\*Dual rated heaters will draw 13% less amps and 25% less wattage when operated at 208V.

### Dimensional Data

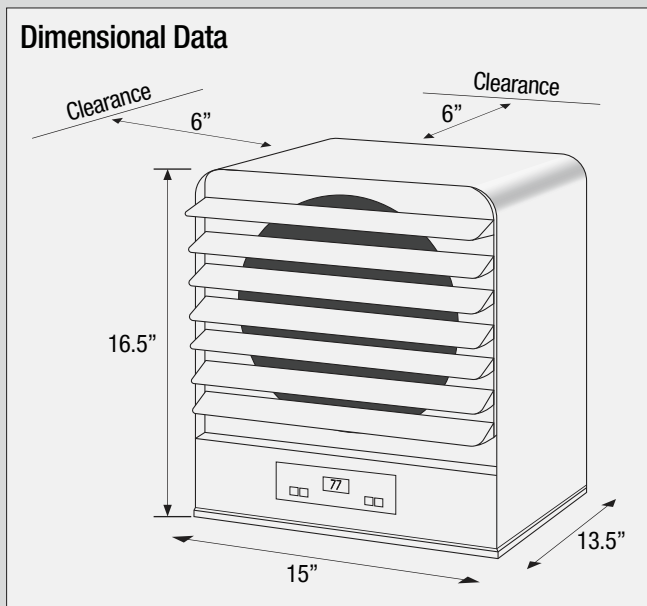

### • KBB-2 Wall/Ceiling Bracket Included

Unit heater brackets can be used for mounting on ceiling or wall. 3/8" threaded hole on top of unit heater can also be used with threaded rod to drop the unit closer to the floor.

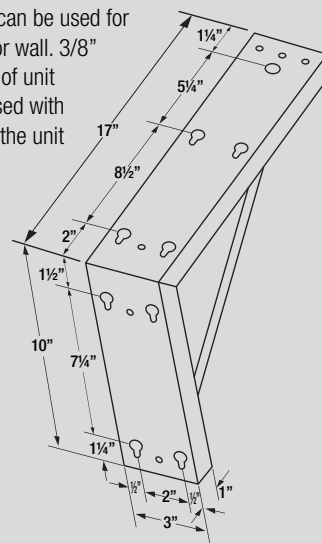

### Energy Saving Eco Comfort

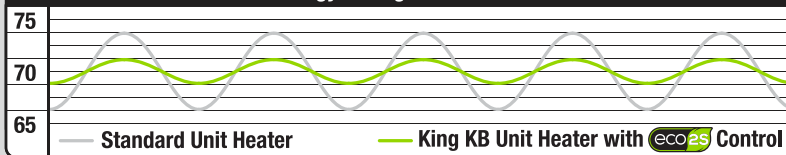

\*Reduces temperature swings