



Stars Management DMCC

SUBMITTAL

BASEBOARD

HEATER

(CB Series)

baseboard heater

CB
SERIES

CONVECTION / CERAMIC ELEMENT CORE

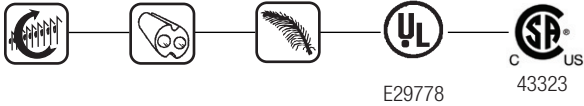

FEATURES:

- Convection Heat
- Ceramic Element
- Quiet Running
- Low density heat
- Backwire design
- Standard color: bright white
- High-grade Nickel-Chromium coil elements with Nickel connectors and stranded Nickel wire
- Fluid-free high mass heating element
- Storage heat core

OPTIONS:

- Color: almond (-A)
- 1-Pole or 2-Pole unit-mount thermostat 45°-80°F operating range
- Manual reset
- 18 gauge front cover for industrial use (see pg. 52)

This baseboard is very different low surface temperature and rugged construction make this a very durable heater suitable for everyday use.

from the standard baseboard. The high mass element has over 50 years experience; It is an excellent alternative to costly and temperamental water or oil-filled baseboard heaters. The ceramic thermal storage core will never leak or explode due to high pressure build-up typical in fluid-filled baseboards. The

If safety, lower surface temperatures and an economical price are your concern, this fluid-less design is the baseboard of choice.

ENGINEERING SPECIFICATIONS:

Contractor shall supply and install CB ceramic baseboard heaters, manufactured by King Electrical Mfg. Company. Heaters shall be of the wattage and voltage as indicated on the plans.

Typical Application: The rugged construction makes this a very durable heater suitable as a primary heat source for everyday use.

Element: The superior performance comes from the proven technology of the ceramic thermal storage heater core. A 7/8" diameter aluminum tube is filled with a special high density ceramic that stores the thermal energy. The oversized fins (4.875 in²) are made from durable (0.015" thick) high grade aluminum which produces better heat transfer than other elements. The benefit of the technology comes when the thermostat is turned off and the element continues to radiate heat. It also reduces temperature swings by heating and cooling more evenly.

Safety: The large heating element and low watt density produce low surface temperatures making it very safe.

Thermal Cutout: A continuous capillary sensor extends the full length of the baseboard, turning the element off when an over temperature

condition occurs. Automatically resets when the normal temperature returns. Optional manual reset available.

Construction: Expansion noise is eliminated by welding the junction boxes and element hangers to the baseboard case. 20 gauge steel adds strength across the entire length of the baseboard.

Quick Wiring: Identical junctionboxes with knockouts in the rear, side and bottom allow the baseboard to be wired from either end. One screw makes quick access to the wiring compartment.

Exterior: Durable baked enamel finish. Colors include standard almond with bright white as an option. Custom colors are available upon request.

Commercial Construction: Optional 18 gauge front cover for commercial use.

Options: Single Pole or Double Pole unit-mount thermostat 45°-80°F.

Quiet: The low temperature element heats cleanly and quietly.

Warranty: 5 year product warranty.

Approvals: UL (E29778), cCSAus (43323)

SELECTION:

| WATTAGE | 120V | | 208V | | 240V | | LENGTH | WT. (lbs.) |
|---------|-----------|--------------------|-----------|--------------------|-----------|--------------------|--------|------------|
| | *MODEL | UPC #093319 PART # | *MODEL | UPC #093319 PART # | *MODEL | UPC #093319 PART # | | |
| 350 | 2CB1203BW | 11205 | 2CB2003BW | 11255 | 2CB2403BW | 11310 | 27" | 7 |
| 500 | 3CB1205BW | 11215 | 3CB2005BW | 11265 | 3CB2405BW | 11320 | 3 ft. | 8 |
| 750 | 4CB1207BW | 11225 | 4CB2007BW | 11275 | 4CB2407BW | 11330 | 4 ft. | 10.5 |
| 1000 | 5CB1210BW | 11235 | 5CB2010BW | 11285 | 5CB2410BW | 11340 | 5 ft. | 13 |
| 1250 | 6CB1212BW | 11245 | 6CB2012BW | 11290 | 6CB2412BW | 11350 | 6 ft. | 16 |
| 1500 | | | 8CB2015BW | 11300 | 8CB2415BW | 11360 | 8 ft. | 20.5 |

* Add suffix (-A) for optional almond finish

1 120V items are NON-CANCELLABLE NON-RETURNABLE (NCNR)

Note: Over 8500 ft Altitude 210 degree high limits will need to be used.

ACCESSORIES:

| *MODEL | DESCRIPTION | UPC #093319 PART # | WT. (lbs.) |
|-----------|--|--------------------|------------|
| BKT1BW | Built-in Single Pole Single Throw Thermostat Kit | 11484 | 1 |
| BKT2BW | Built-in Double Pole Single Throw Thermostat Kit | 11488 | 1 |
| BKT1BW-TP | Built-in Tamperproof Single Pole Single Throw Thermostat Kit | 11542 | 1 |
| BKT2BW-TP | Built-in Tamperproof Double Pole Single Throw Thermostat Kit | 11544 | 1 |
| -MR | Manual Reset | | |

* Add suffix (-A) for optional almond finish

MODEL CODE:

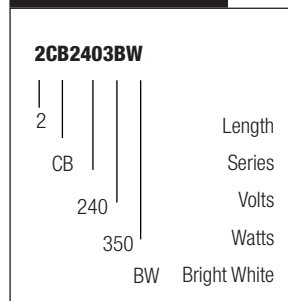

Standard Color: Bright White

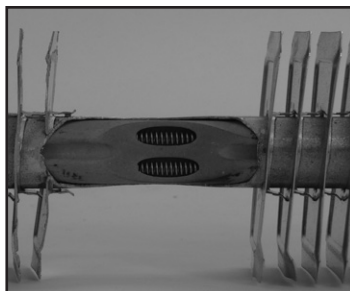
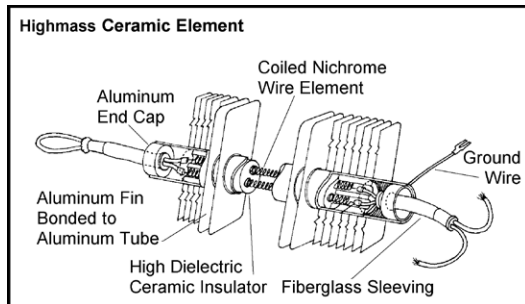

High Mass Core

DIMENSIONS:

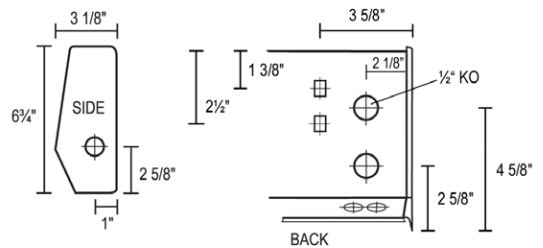

⊕ = Knockout Location

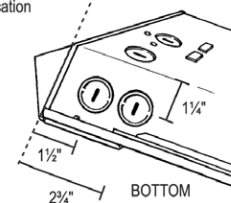

Junction boxes showing knockouts





CB SERIES BASEBOARD HEATER INSTALLATION GUIDE

ATTENTION: Before attempting to install your heater, verify that the power supply wires are the same voltage as the heater you are installing. The best way to check for proper voltage is by using a voltmeter, testing between supply line 1 and 2. **240 and 120 Volt heaters are not interchangeable.** Connecting a 240 Volt heater to a 120 Volt circuit will reduce the wattage 75% making the heater feel barely warm. Connecting a 120 Volt heater to a 240 Volt circuit will destroy the heater, could cause fire damage, personal injury or death, and, voids all warranties.

WARNING: Turn off power source to the heater before attempting installation, maintenance or repairs. Lock, tape or tag circuit breaker or fuse so that power cannot be turned on by accident. Failure to do so could result in serious electrical shock, burns or possible death.

PLACEMENT: When possible baseboard heaters should be placed on an outside perimeter wall under a window. This is due to the fact that the outside wall is usually the spot of greatest heat loss. A baseboard heater may sit directly on any floor surface including carpet. Do not allow carpet to block air intake at bottom.

GENERAL SAFETY INFORMATION: Keep electrical cords, any bulky furniture or other household items that could restrict airflow away from heater. Refer to clearance diagram for drapes. Do not install heater below an electrical outlet or against vinyl wallpaper, paperboard or low density fiberboard surfaces. Do not recess mount heater. Do not mount heater vertically. Do not store flammable liquids in vicinity of the heater. Installation must comply with applicable national and local electrical codes. Protect electrical supply wire from nicks, sharp objects, oil, grease or other chemicals that could damage the insulation.

INSTALLATION INSTRUCTIONS:

1. Make sure heater is positioned on the wall with the "Bottom" label facing the floor. Mounting upside down could be a hazard.
2. Remove junction box cover from left or right end. The heater can be wired from either end.
3. Remove knockout and pull supply wires through. Use a cable fitting to secure the power wires.
4. Locate wall studs and secure heater to wall with a nail or screw. Use the mounting dimples in the back can to position the fastener. The dimples will prevent the fastener from slipping when applying pressure to pierce the metal back can. You do not have to remove the cover or reflector to mount the heater.
5. Connect electrical wires and groundwire to the heater per the appropriate wiring diagram on following pages.

CLEARANCE MINIMUMS FOR DRAPES

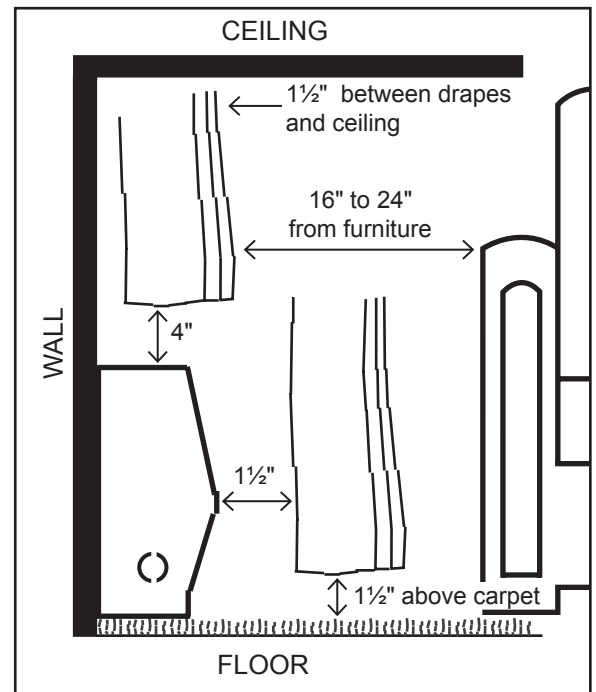

CIRCUIT SIZING TABLE

| AMPS | VOLTS | WATTS | WIRE SIZE | CIRCUIT PROTECTION |
|------|-------|-------|-----------|--------------------|
| 12 | 120 | 1,440 | #14/2 | 15 Amp - 1 Pole |
| 16 | 120 | 1,920 | #12/2 | 20 Amp - 1 Pole |
| 12 | 240 | 2,880 | #14/2 | 15 Amp - 2 Pole |
| 16 | 240 | 3,840 | #12/2 | 20 Amp - 2 Pole |
| 24 | 240 | 5,700 | #10/2 | 30 Amp - 2 Pole |

WIRING INSTRUCTIONS FOR SINGLE POLE THERMOSTATS

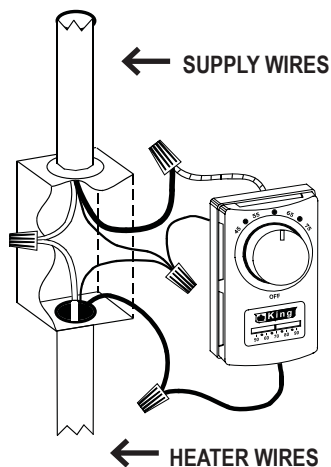

Single Pole
K601
HE-1
HET-1
S22

| WIRE COLOR CHART | |
|------------------|-----------------|
| | BLACK WIRE |
| | RED WIRE |
| | BARE GROUNDWIRE |
| | WHITE WIRE |

Connection Diagram for Wall Mounted Thermostat

1. Red thermostat wire to black power supply wire.
2. Black thermostat wire to black heater wire.
3. White power supply wire to white heater wire.
4. Connect all bare groundwires together.

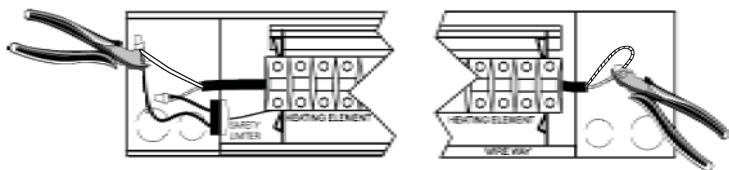

Cut one wire to Apply Power to LEFT SIDE

Cut one wire to Apply Power to RIGHT SIDE

Instructions for Left or Right Side Wiring Connection

1. *Caution:* Do not cut both factory splice caps on left side! You need only two wires for power connection.
2. Heater can be wired from either side - wire one side only.
3. Cut only one factory splice cap or loop wire as shown.
4. This leaves two wires for power connection.



Power Supply Connection LEFT SIDE

Power Supply Connection RIGHT SIDE

Connection Diagram when using a Wall Thermostat

1. Connect power supply wires from wall thermostat as shown.
2. Black and white supply wires can be connected to the heater in reverse order. For simplicity the most common method is shown.
3. Connect bare groundwire to green groundwire.



Built-in (BKT-1) Diagram LEFT SIDE

Built-in (BKT-1) Diagram RIGHT SIDE

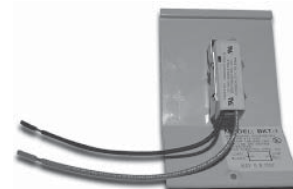

BKT-1

Connection Diagram for BKT-1 Thermostat

1. Mount thermostat per instructions.
2. Red thermostat wire to black supply wire.
3. Black thermostat wire to heater.
4. White supply wire to heater.
5. Bare groundwire to green groundwire.

WIRING INSTRUCTIONS FOR DOUBLE POLE THERMOSTATS

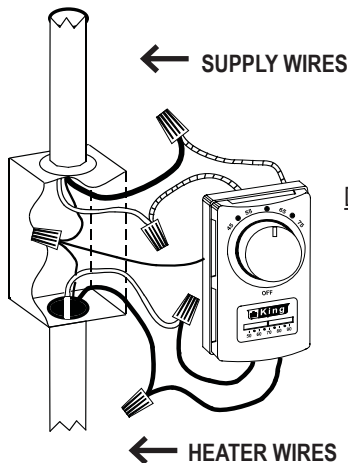

Double Pole
D22
K602
HE-2
HET-2

| WIRE COLOR CHART | |
|------------------|-----------------|
| | BLACK WIRE |
| | RED WIRE |
| | BARE GROUNDWIRE |
| | WHITE WIRE |

Connection Diagram for Wall Mounted Thermostat

1. Connect the two red thermostat wires to the black and white power supply wires.
2. Connect the two black thermostat wires to the black and white heater wires.
3. Connect all the bare groundwires together.

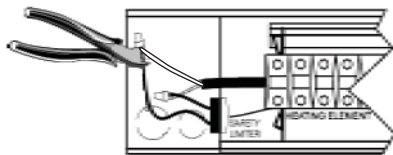

Cut one wire to Apply Power to LEFT SIDE

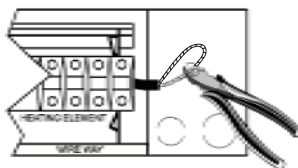

Cut one wire to Apply Power to RIGHT SIDE

Instructions for Left or Right Side Wiring Connection

1. *Caution:* Do not cut both factory splice caps on left side! You need only two wires for power connection.
2. Heater can be wired from either side - wire one side only.
3. Cut only one factory splice cap or loop wire as shown.
4. This leaves two wires for power connection.

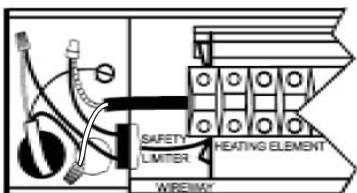

Supply Power Connection LEFT SIDE

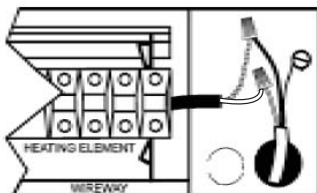

Power Supply Connection RIGHT SIDE

Connection Diagram when using a Wall Thermostat

1. Connect power supply wires from wall thermostat as shown.
2. Black and white supply wires can be connected to the heater in reverse order. For simplicity the most common method is shown.
3. Connect bare groundwire to green groundwire.

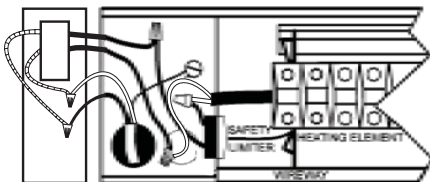

Built-in (BKT-2) Diagram LEFT SIDE

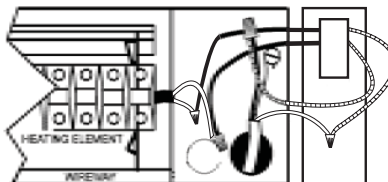

Built-in (BKT-2) Diagram RIGHT SIDE

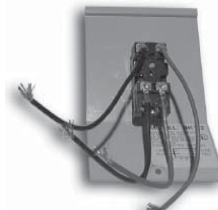

BKT-2

Connection Diagram for BKT-2 Thermostat

1. Mount thermostat per instructions.
2. Connect the two red thermostat wires to the black and white supply wires.
3. Connect the two black thermostat wires to the two heater wires.
4. Bare groundwire to green groundwire.

COMMONLY ASKED QUESTIONS

Q. Will the room heat up faster with the thermostat turned up to 90 degrees?

A. No, the heater is always on full wattage when the thermostat is below the pre-set temperature. The thermostat shuts off when the pre-set temperature is reached, therefore set the thermostat to the desired comfort level, not above.

Q. Will the electricity bill be lower using 240V heaters?

A. No, electricity is billed by kilowatt hours, voltage makes no difference. Typically, baseboard heaters are 240V because of wiring capacity, i.e. 240V heaters draw less Amps than 120V heaters.

Q. What is the difference between a two pole and a single pole thermostat?

A. A 1-P thermostat has no positive off position. That means when the knob is turned all the way to the left (counterclockwise) it has a low

setting. A 2-P thermostat breaks an additional line when the knob is turned to the off position. The heater will not turn on with the knob in the off position.

Q. Can the baseboard heater be painted?

A. Yes. A semi or gloss latex enamel will hold up to the heat but will not last as long as the original baked enamel finish.

Q. How much heat do I need?

A. A general rule of thumb is 10 Watts for every square foot of floor space. For example: A 10' x 10' room is 100 ft² (10 w/ft² x 100 ft²) and would require 1000 Watts of heat. If you live in a cold climate or if the room has a ceiling height above 8 feet use up to 15 w/ft².

TROUBLESHOOTING CHART FOR BASEBOARD HEATERS

| SYMPTOM | PROBLEM | SOLUTION |
|--|--|---|
| Breaker trips | <ol style="list-style-type: none"> 1. Short circuit 2. Overloaded circuit 3. Improper voltage | <ol style="list-style-type: none"> 1. Find source of short. Trace heater circuit and verify the heater is wired properly. 2. Reduce wattage in circuit. Refer to circuit sizing table for maximum wattage. 3. Verify the heater voltage matches the supply voltage. |
| Heater not working | <ol style="list-style-type: none"> 1. No power 2. Loose connections 3. Defective limit | <ol style="list-style-type: none"> 1. Turn breaker on. Turn thermostat on. Check that the breaker is positioned properly on panel bus-bar. A 2-Pole breaker must be connected to both bus-bars (A & B phase) to produce 240V power. 2. Tighten wire connections. 3. By-pass the limit to test. If heater works, replace the limit. |
| Heater smokes | <ol style="list-style-type: none"> 1. Oil on element 2. Needs cleaning | <ol style="list-style-type: none"> 1. It is normal for the element to burn off some light finishing oil used in the manufacturing process when first energized. Open windows and allow room to vent until it stops, usually within a few minutes. 2. Remove any dust or dirt accumulation. |
| Room temperature does not match thermostat setting | <ol style="list-style-type: none"> 1. Thermostat affected by another heat source 2. Improper calibration | <ol style="list-style-type: none"> 1. Sunlight or other heat sources can affect the thermostat. Move thermostat to another location or remove the heat source. 2. Remove cover and adjust calibration screw. |
| Room temperature swings from too hot to too cold | <ol style="list-style-type: none"> 1. Defective or low quality thermostat | <ol style="list-style-type: none"> 1. Replace with a better quality thermostat. Anticipated thermostats are fairly accurate; an electronic thermostat is the best. |

Maintenance: The high quality and superior design of this heater will provide years of trouble-free performance. Each year the heater should be checked and cleaned for lint and dust accumulation. King recommends using a soft bristled brush or a can of compressed air to knock off contaminants, then vacuum out the debris.

Warranty: King Electrical Mfg. Co. will repair or replace without charge to the original owner any baseboard heater found to be defective or malfunctioning for 5 years from the date of purchase. If the product becomes defective within the warranty period contact King at 800-603-5464 for instructions on how to repair or replace the heater. Do not return the heater to the store. Products returned without authorization will be refused.